

Mounting instructions alpha Racing conversion kit switch gear BMW S1000RR 2009-2014

Attention: When using the original BMW throttle kit, the retaining tab must be shortened. We recommend the fast throttle kit (Art. No.: 3271A004B01).

1. Remove the original switch unit on the left side.

- Loosen the two safety bars (1) and remove the cover (2)
- Remove the screw (3) and turn the handle unit forwards (4) (Figure 1)

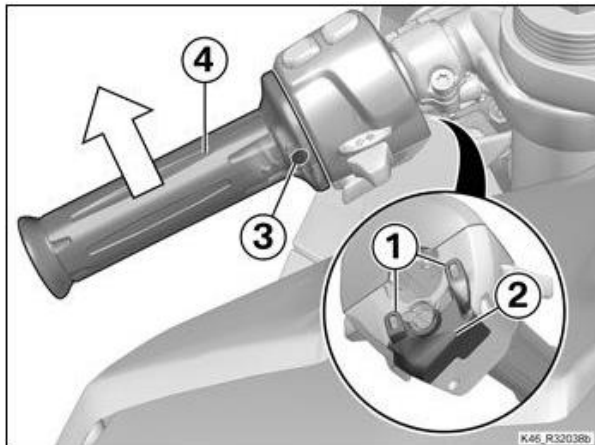

Fig. 1

- Loosen the small connector (5)
- Loosen the big connector (6)

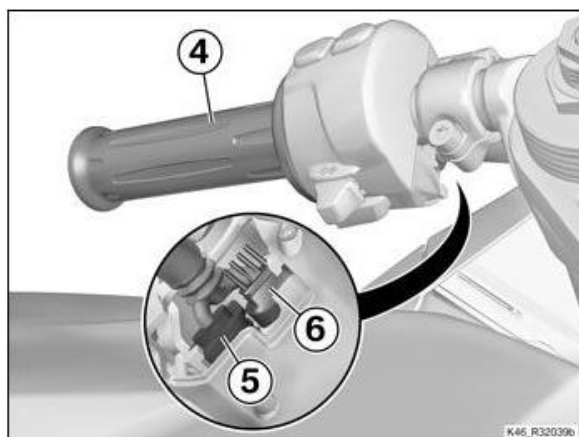

Fig. 2

- Press the retaining tab (2) upwards to release the switch unit from the fast throttle kit (Figure 3)
- Remove the throttle kit and the switch unit from the handle bar

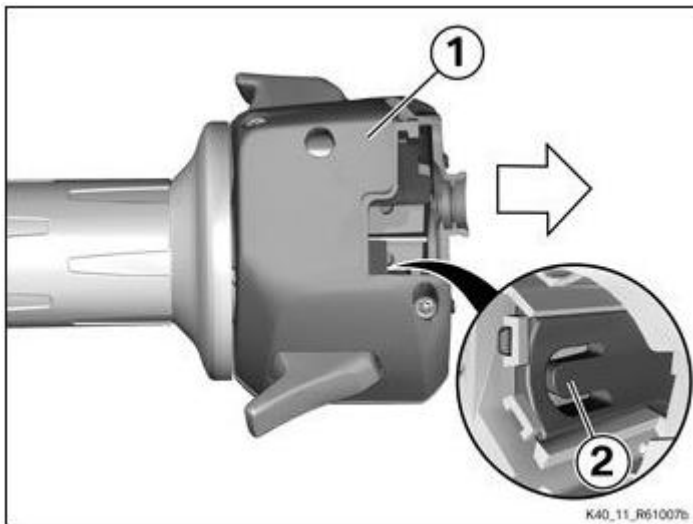

Fig. 3

2. Mount the left switch unit on the handle bar (Figure 4) and connect the plugs to the wiring harness. The 2-pin connector for the throttle kit heater is omitted (Figure 5).



Fig. 4



Fig. 5

- Open the outer heat shrink tube shown in figure 6 by approx. 10 cm, so that the cables can be routed neatly



Fig. 6

3. Remove the throttle kit and the switch unit on the right side

- Loosen the screw (1) and open the cover (2) by pulling down slightly until the switch is open (Figure 7)

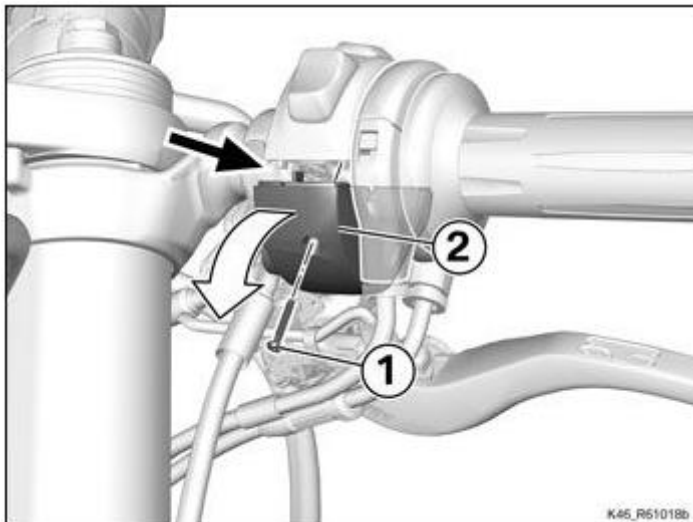

Fig. 7

- Press the cover (2) upwards and remove it (pay attention to the retaining tabs (3)) (Figure 8)

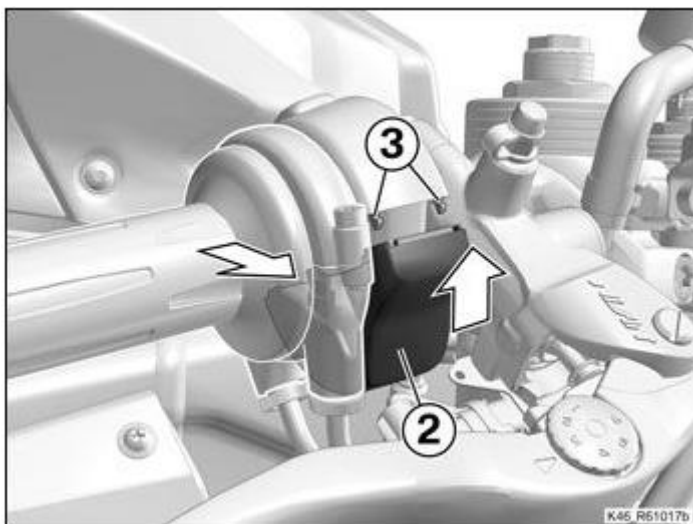

Fig. 8

- Loosen the connector (1) of the switch unit
- Loosen the screws (2) and then remove the switch unit (3) (Figure 9)

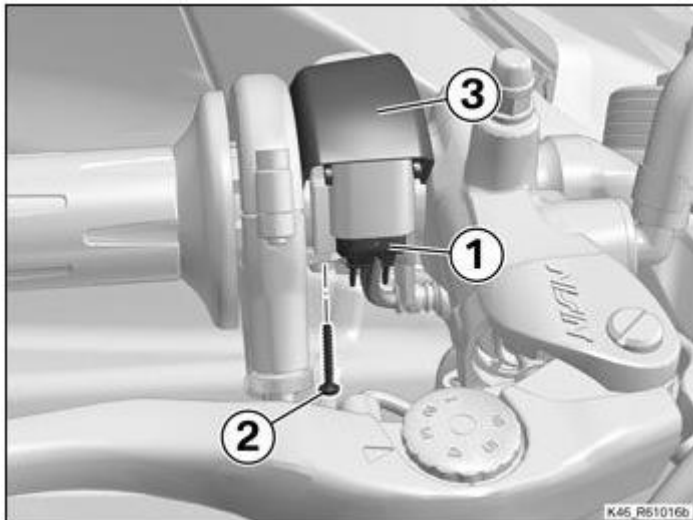

Fig. 9

- Remove the screw (1) and remove the cover (2)
- Loosen the adjusting screw and set the maximum clearance
- Loosen the retaining nut (Figure 10)

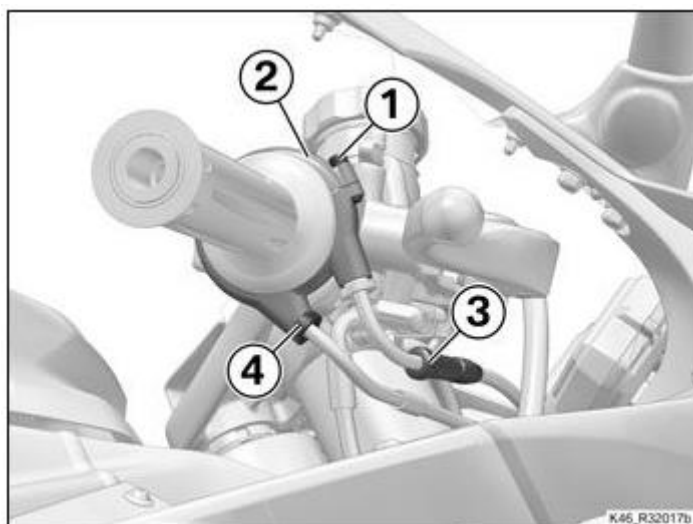

Fig. 10

- Remove the screw (1)
- Hang out the throttle cable (2)
- Loosen the retaining nut (3)
- Move the throttle kit (4) and hang out the throttle cable (5)
- Release the throttlekit (4) from the handle bar (Figure 11)

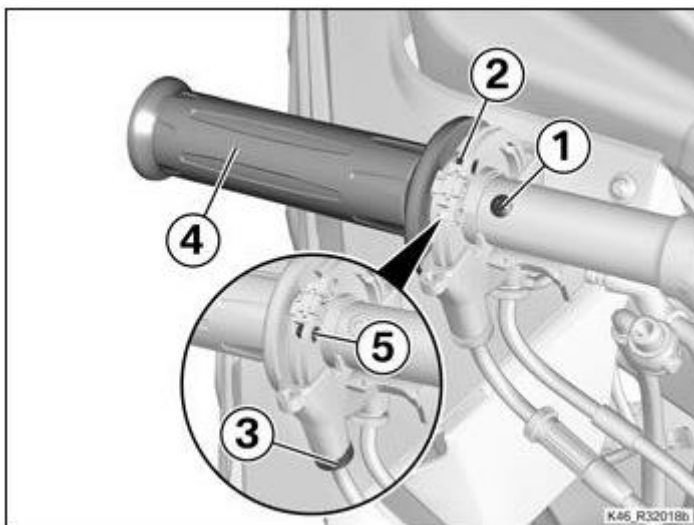

Fig. 11

Attention: When using the OEM throttle kit, the retaining tab must be shortened for attachment to the handlebar so that there is sufficient space for the right switch unit (Figure 12). The tab must be shortened as indicated to the right of the marked thread.

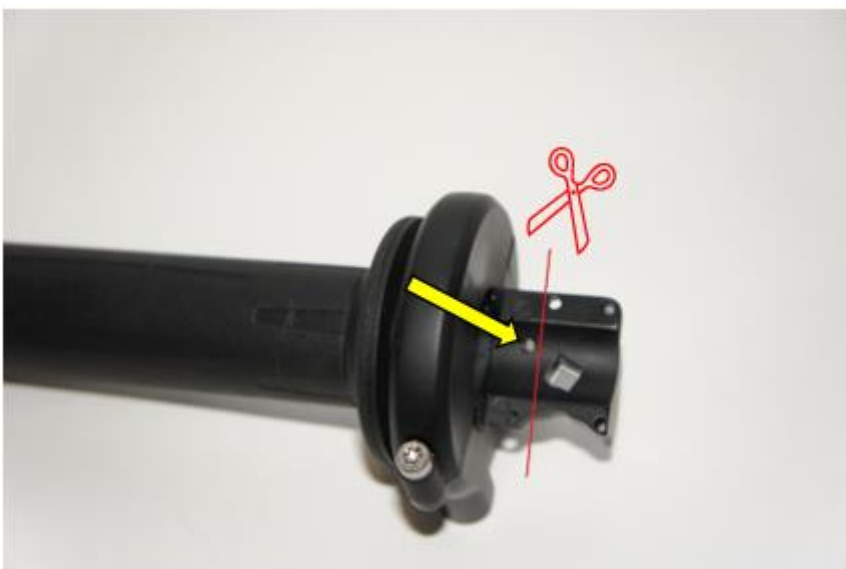

Fig. 12

- Then install the throttle housing and the switch unit (Figure 13). Make sure that the throttle cable is routed in the same housing as it was previously installed in the OEM housing. Connect the plugs of the switch unit to the wiring harness (Figure 14) (the throttle kit heater plug disappears here).



Fig. 13

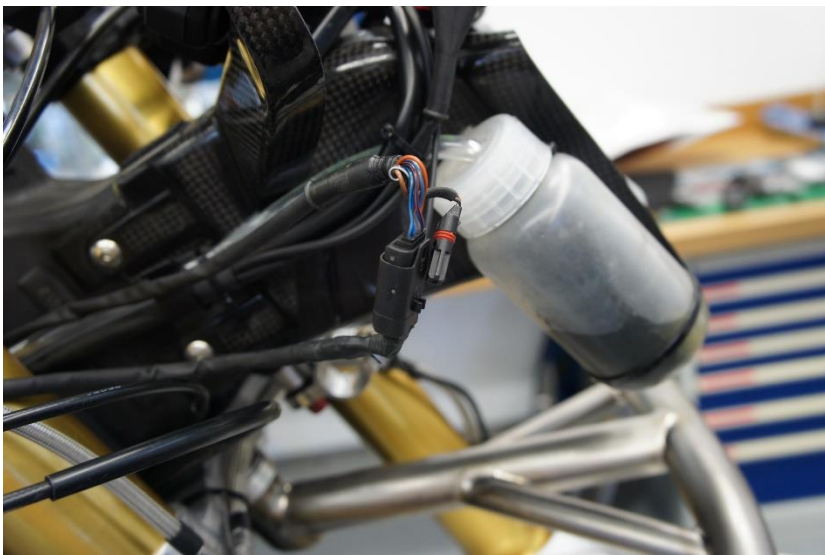

Fig. 14

5. Connect the connectors of the right and left switch units together (Figure 15).



Fig. 15

6. Finally, fix the cables of the switch units with the supplied cable ties.

The left switch unit includes the following functions:

- ABS/DTC
- Mode
- Lap (Flashlight)
- Up (Trip)
- Down (Set)